

### Typical Features

- ◆ Fixed input voltage, Isolated & unregulated output, Output power 2W
- ◆ High Efficiency up to 86%
- ◆ Small compact SIP packing
- ◆ No external component required
- ◆ Isolation Voltage 1500VDC
- ◆ Operating Temperature: -40℃~+85℃
- ◆ Plastic Case, meet UL94 V-0 standard



**Test Condition:** Unless otherwise specified, data in the datasheet should be tested under the conditions of inputting nominal voltage, pure resistance rated load and Ta=25℃

### Application Field

*It could be widely used for instrument, communication, pure digital circuit, general low frequency analog circuit, relay drive circuit, data exchange circuit, etc.*

### Typical Product List

Model	Input Voltage Range (VDC)		Output Voltage/ Current (Vo/Io)		Input Current(mA) Nominal Voltage		Max. Capacitive Load uF	Ripple & Noise (Max.) mVp-p	Efficiency (%)full load, input nominal voltage	
	Nominal	Range	Voltage (VDC)	Current(mA) MAX./Min.	Full load Typ.	No Load Typ.			Min.	Typ.
FN2-05S3V3CN	5	4.5 - 5.5	3.3	600	533	50	470	150	75	79
FN2-05S05CN			5	400	519	50	470	150	80	84
FN2-05S09CN			9	220	513	50	470	150	75	79
FN2-05S12CN			12	167	513	50	470	150	80	84
FN2-05S15CN			15	133	506	50	470	150	80	84
FN2-05S24CN			24	83	506	50	470	150	80	84
FN2-12S05CN	12	10.8 - 13.2	5	400	208	20	470	150	76	80
FN2-12S09CN			9	220	183	20	470	150	78	82
FN2-12S12CN			12	167	183	20	470	150	80	84
FN2-12S15CN			15	133	187	20	470	150	80	84
FN2-12S24CN			24	83	186	20	470	150	80	84
FN2-15S05CN	15	13.5-16.5	5	400	164	10	470	150	78	82
FN2-24S3V3CN	24	21.6 - 26.4	3.3	600	113	10	470	150	75	79
FN2-24S05CN			5	400	108	10	470	150	76	80
FN2-24S09CN			9	220	107	10	470	150	82	86



FN2-24S12CN			12	167	105	10	470	150	80	84	
FN2-24S15CN			15	133	105	10	470	150	82	86	
FN2-24S24CN			24	83	105	10	470	150	82	86	
NN2-05D3V3CN	5	4.5	±3.3	±303	485	80	220	150	75	79	
FN2-05D05CN			±5	±200	519	50	220	150	76	80	
FN2-05D09CN		-	±9	±110	513	50	220	150	80	84	
FN2-05D12CN		5.5	±12	±83	458	28	220	150	80	84	
FN2-05D15CN			±15	±67	506	50	220	150	78	82	
FN2-12D05CN			12	10.8	±5	±200	214	18	220	150	76
FN2-12D09CN		±9			±110	211	18	220	150	78	82
FN2-12D12CN	-	±12		±83	211	18	220	150	80	84	
FN2-12D15CN	13.2	±15		±67	216	18	220	150	80	84	
NN2-15D15CN	15	13.5-16.5	±15	±67	160	18	220	150	80	84	
FN2-24D05CN	24	21.6	±5	±200	108	18	220	150	76	80	
FN2-24D09CN			±9	±110	107	18	220	150	82	86	
FN2-24D12CN		-	±12	±83	105	18	220	150	80	84	
FN2-24D15CN		26.4	±15	±67	105	18	220	150	80	84	

Note: In order to ensure the converter can work reliably with high efficiency, the minimum load should not less than 10% rated load when it is used. If the needed power is indeed small, please parallel a resistor at the output side, the resistance recommended equal to 10% nominal power.

**Input Specifications**

Item	Working Conditions	Min.	Typ.	Max.	Unit
Input Overshoot Voltage (1 Second.max.)	5Vdc Input	-0.7	--	9	VDC
	9Vdc Input	-0.7	--	15	
	24Vdc Input	-0.7	--	30	
Input Filter	Capacitor Filter				

**Output Specifications**

Item	Working Conditions	Min.	Typ.	Max.	Unit	
Output Power		0.2	--	2	W	
Output Voltage Accuracy	Nominal input, Full load	--	±2	±5	%	
Load Regulation	10% ~ 100% nominal load	3.3Vdc output	--	--		20
		Other output	--	--		15
Line Voltage Regulation	Input Voltage Change±1%	3.3Vdc output	--	--		±1.5
		Other output	--	--	±1.2	



Ripple & Noise①	Nominal input,full load, 20MHZ bandwidth	--	100	150	mVp-p
Temperature Drift Coefficient	100% Full Load	--	--	±0.03	%/°C
Output Short Circuit Protection	Continuous short-circuit protection, self-recovery				

NOTE:①Ripple & Noise tested by twisted-pair method;

**General Specifications**

Switching Frequency (Full load)	3.3Vdc/5Vdc Input	260KHz (Typ.)
	12Vdc/24Vdc Input	450KHz (Typ.)
Operating Temperature	Refer to Temperature Derating Curve	-40°C ~ +85°C
Storage Temperature		-55°C ~ +125°C
Shell temperature rise during work	Within Temperature Derating Curve	25°C(Typ.)
Relative Humidity	No condensing	5%~95%
Case Material		Black flame-retardant heat-resistant Plastic(UL94 V-0)
Pin Withstand Soldering Temp	Distance to Case 1.5mm, 10S	300°C MAX
Isolation Voltage	Test 1 minute, leakage current < 0.5mA	1500Vdc
Isolation Capacitor	Input/Output,100KHz/0.1V	20 pF (Typ.)
MTBF	MIL-HDBK-217F@25°C	35X10 <sup>5</sup> Hrs
Product Weight		2.5g (Typ.)
Packing	Tube(525*18*10mm)	25PCS
	Box(542*110*155mm)	2000PCS(Total 80 tubes)

**Packing Dimension**

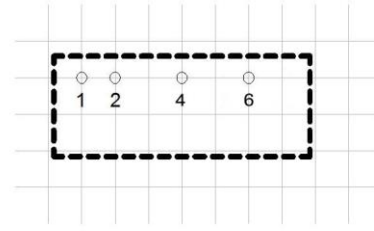
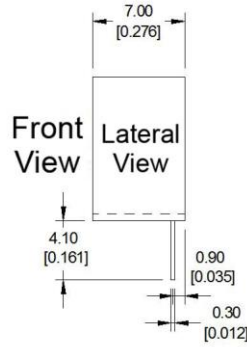
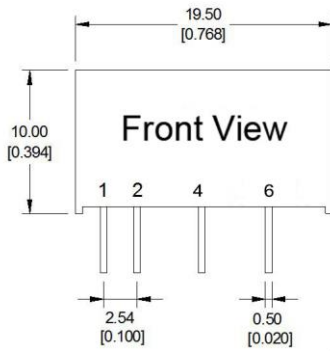

Print board vertical view  
Grid: 2.54mm(0.1inch)

Unit: mm  
General tolerance: 0.xx±0.1(0.xx±0.004)  
Pin section tolerances: ±0.25(0.xx±0.01)

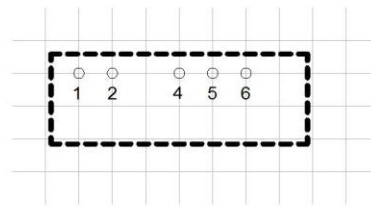
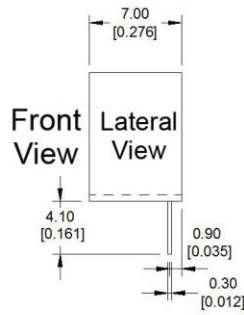
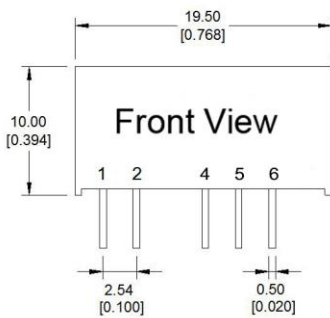

Print board vertical view  
Grid: 2.54mm(0.1inch)

Unit: mm  
General tolerance: 0.xx±0.1(0.xx±0.004)  
Pin section tolerances: ±0.25(0.xx±0.01)

Packing Code	L x W x H	
C	19.50x7.00 x 10.00mm	0.768 x 0.276 x 0.394inch

**Pin Function**

Pin Function	1	2	3	4	5	6
Single (S)	+Vin	GND	--	-Vo	--	+Vo
Dual (D)	+Vin	GND	--	-Vo	COM	+Vo

Note: if the definition of pin is not in accordance with the model selection manual, please refer to the label on actual item.

**Ripple & Noise Test: (Twisted Pair Method 20MHz bandwidth)**

Test Method:

a. 12# twisted pair to connect, Oscilloscope bandwidth set as 20MHz, 100M bandwidth probe, terminated with 0.1uF polypropylene capacitor and 10uF high frequency low resistance electrolytic capacitor in parallel, oscilloscope set as Sample pattern.

b. Input terminal connect to power supply, output terminal connect to electronic load through jig plate, Use 30cm±2 cm sampling line, Power line selected from corresponding diameter wire with insulation according to the flow of output current.

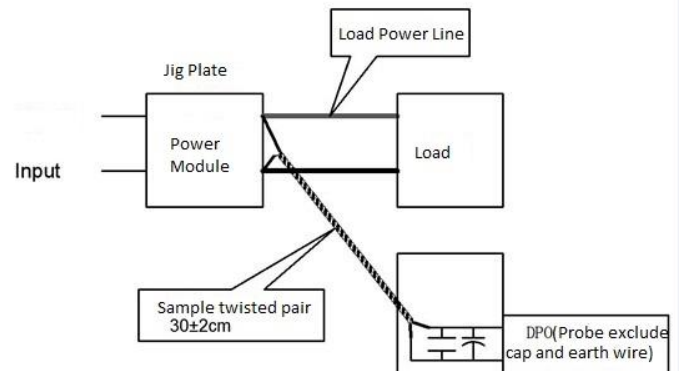

**Temperature Curve**

### Temperature Derating Curve

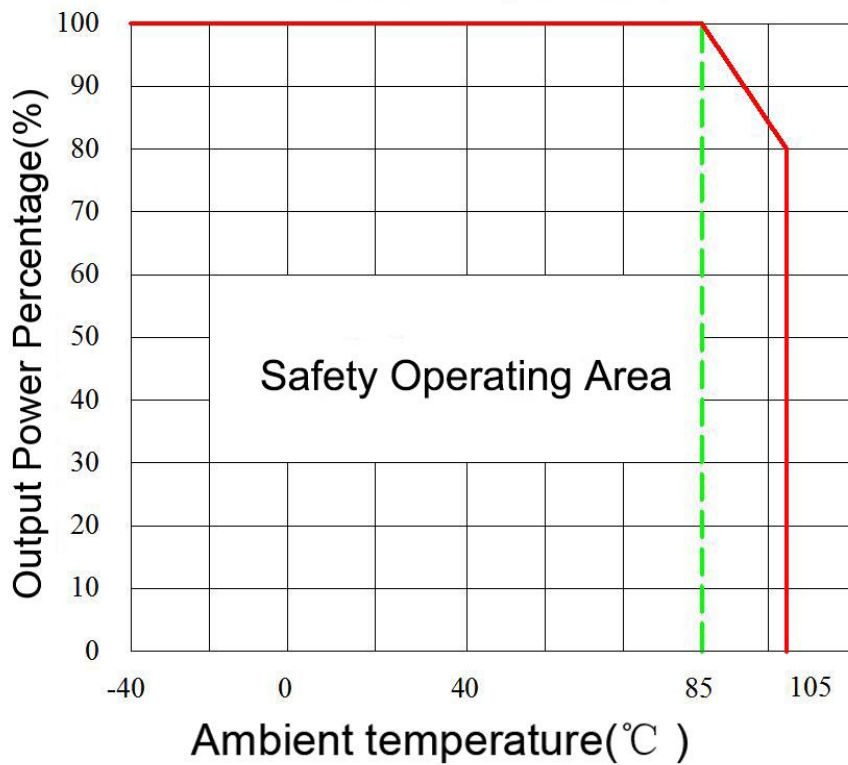

### Design and Application Circuit Recommended

#### 1. Output load requirements

- a. In order to ensure the converter can work reliably with high efficiency, the minimum load should not less than 10% rated load when it is used. If the needed power is indeed small, please parallel a resistor at the output side, the resistance equal to 10% nominal load.
- b. The maximum capacitive load is tested under nominal input full load, and cannot exceed the maximum capacitive load of output terminal under operation, otherwise it will cause it difficult to start up and damage the product.

#### 2. Recommended circuit

In order to ensure the input/output ripple and noise decreased, capacitor filter net could be connected to input and output terminal, application circuit as below photo 1; choosing suitable filter capacitor is very important, start-up problems may be caused by too large capacitance. To ensure the modules running safely and reliably, the recommended capacitive load values as shown in Table 1. (But for the actual output power of application circuit is less than 0.5W, suggest not to connect external capacitor)

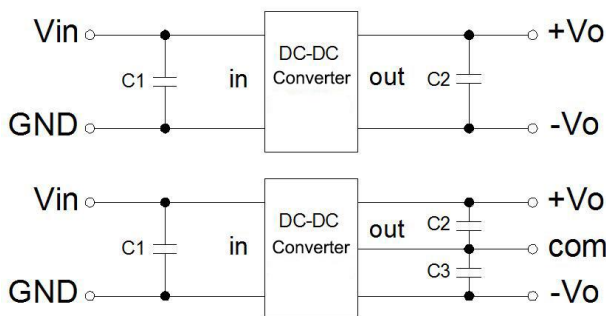

Recommended capacitive load value (Table 1)

Vin (Vdc)	C1 (μF)	Vout (Vdc)	C2 (μF)	Vout (Vdc)	C2, C3 (μF)
3.3/5	4.7	3.3/5	10	±3.3/±5	4.7
12	2.2	9	4.7	±9	2.2
15	1	12	2.2	±12	1
24	1	15	1	±15	0.47
--	--	24	0.47	±24	0.22



### 3. Output regulated voltage and over voltage protection circuit

The simplest device to protect output regulated voltage, over voltage and over current is to cascade a linear regulator with overheat protection at input or output terminal, and connect a capacitor filter net(see below picture), filter capacitive value recommended see table 1, Linear regulator is chosen according to the actual voltage, current needed in working, or choose our NW series products.

Single Output

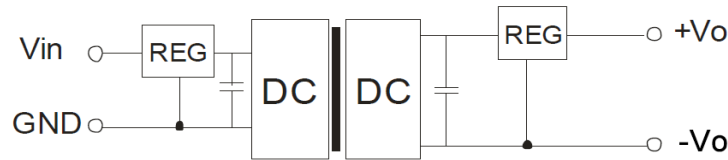

#### Note:

- 1.This product cannot be used in parallel, and do not support hot-plugging;
- 2.If the product works below the minimum required load, it cannot guarantee that the product performance meets all performance indicators in this manual;
3. All index testing methods in this datasheet are based on our Company's corporate standards
4. The product specification may be changed at any time without prior notice.